

TIN KNOCKER

TK 20 GA. BUTTON LOCK ROLLFORMER

INSTRUCTIONS & PARTS DIAGRAM



TAAG MACHINERY CO.

(Master Distributor)

1257-B Activity Dr.

Vista, CA 92081

Tel: (800) 640-0746 Fax: (760) 727-9948

Website: www.tinknocker.com * Email: taag@sbcglobal.net

TIN KNOCKER SAFETY RULES BUTTON LOCK

1. **WARNING:**

Electrical Danger---Misuse or improper installation of machinery connected to a source of electricity may result in accidental shock that could cause injury or death. Installation must conform to National Electric Code (Article 250-Grounding, etc.)

A trained and qualified electrician must make electrical connections. Electrical characteristics shown on motor plate and control panel must match the power source; and all electrically powered equipment must be grounded.



2. **WARNING:**

Mechanical Danger- The power driven forming rolls rotate at all times when power is supplied to the motor. Never place any part of the body including loose clothing near or onto the rotating rolls. (KEEP HANDS AWAY). Failure to comply will lead to personal body injury.



3. Never clean forming rolls while rolls are rotating—turn power off to clean rolls.
4. Machine to be operated by authorized personnel who have been trained by their supervisor with the working and safety features of the machine, and by reading and understanding the Operator's Manual.
5. Do not operate Roll former without reading operator's Manual and without proper supervisory instructions.
6. Perform all installation and set-up operations before applying power for electrical start-up.

7. Never operate machine with any guard removed; i.e., all required guarding to be installed and effective. Do not override the safety features of the equipment. Do not remove, paint over, alter, or deface any machine-mounted warning and instruction plates and signs.
8. Never leave machine running unattended. When not in use, turn off electrical power.
9. Never adjust machine with power on.
10. Avoid accidental start-up.
11. Do not use machine if servicing is required.
12. Use safety glasses and required protective tools.
13. Keep work areas clean and in proper order.
14. Be alert to all potential hazards. Notify your supervisor whenever you feel there is a hazard involving the equipment or the performance of your job.

WARRANTY

All new machines are sold with a one-year limited warranty, on factory defective parts. The warranty is limited to the original user. TAAG Machinery Co. at its option, will repair, replace or refund the purchase price of any part, tool or machine that fails during the warranty period. TAAG Machinery Co. will pay normal shipping charges for replacement parts. After 90 days from date of purchase, all express or overnight delivery charges are the responsibility of the customer. Purchaser must deliver to TAAG Machinery Co., at the address below, any written claim, with proof of original purchase. Replacement parts will be invoiced to purchaser and credit issued when the failed part is delivered to TAAG Machinery Co. Removal, reinstallation or replacement parts shall be at purchasers' / user's expense. Failure due to improper use of the machine voids the warranty.

NOTE: 1. This machine has been tested and adjusted prior to shipment, but can and often does require readjustment due to vibration and bouncing during transport. Following the procedures described within can easily do readjustment. These are procedures with which you, as a user, should be familiar, as you will use them repeatedly over the life use of the machine. If you have difficulty in performing these procedures, we are here to support you. Call us at: (800) 640-0746.

TAAG MACHINERY CO.

(Master Distributor)

1257-B Activity Dr.

Vista, CA 92081

Tel: (800) 640-0746 Fax: (760) 727-9948

Website: www.tinknocker.com * Email: taag@sbcglobal.net

Button Lock Machine

CAPACITY: 20 gauge and lighter.

MATERIAL REQUIREMENTS PER LOCK:

Receiver Lock, 1-5/16".

Button Flange (90 deg.), 7/16".

Total amount of metal, 1-3/4". This amount is to be added to formed sections for calculation of sheet sizes. The above dimensions can be somewhat modified by varying the entrance gauge settings to suit the requirements of a specific project or material.

ELECTRICAL:

Standard electrical: 3 H.P. 220 volts, 60 cycle, 3-phase motor and starter. (Optional 5 H.P. 230 volts, 60 cycles, 1 phase motor.)

OPERATION:

Start machine and feed material into either roll set by holding the material flush against the gauge and feeding material into the rolls. Keeping the material with the same side up, run the second lock on the opposite side of the sheet. Check the end results and adjust accordingly if locks are not satisfactory.

RECEIVER LOCK ADJUSTMENT

(INBOARD Roll Set):

The main adjustments affecting the receiver lock are three hold down studs that pass through the spacer bars. They are stamped (on top) No. 1, No. 2 and No. 3 the entrance and exit gauge bar settings. To adjust the three hold down studs proceed as follows:

WARNING

Check voltage and phase before starting machine. Feed sheet of material into either roll set holding the material flush against the gauge. Keeping the material with the same side up, run second lock on opposite side of the sheet.

1. Loosen the 1/4" lock screws on the three hold down studs.
2. Tighten the three hold down studs (No. 1, No. 2 and No. 3) until firm resistance is met.
3. Loosen the No. 1(entrance end) 1/8 to 1/4 turn.
4. Loosen the No. 2 studs (center) 1/4 to 1/2 turn.
5. Loosen the No. 3 Stud (exit) 3/8 to 1/2 turns.

Run a piece of material through the machine and check the results. If the setting proves satisfactory, tighten the two 1/4" lock screws and proceed with the operation of the machine.

FLANGE BUTTON LOCK: (Auxiliary Rolls)

The two 3/8 studs that pass through the plates and the auxiliary side of the machine are the adjustment points for forming the 90 Deg. Flange. To adjust the auxiliary rolls proceed as follows:

1. Tighten the two hold down studs until firm resistance is met.
2. Loosen 1/4 to 1/2 turn.

If the material shows signs of stretch or excessive pressure loosen studs slightly. The material should emerge from the machine with a properly formed angle to obtain 90 deg. duct corners when locks are snapped together. The angle can be controlled by the location of the top number eight forming roll on the shaft and the positioning in or out of the idler bracket located at the seventh and eighth roll station. To adjust the above proceed as follows:

1. Remove the two idler bracket-retaining cap screws. Note shims are placed between the bracket and the plate. Shims may range from .020 to .030 to insure proper flange.
2. Remove top and bottom #8 roll station.
3. To increase angle of formed flange add from .010 to .040 shims 22 mm I.D. on the roll shaft.
4. Place the roll onto the shaft securely by tightening setscrew.
5. Replace bottom #8 roll.
6. Replace idler bracket assembly.

If angle is less than 90 deg. then too much pressure is applied by the top 8 roll or idler bracket rollers. Adjust roller and bracket to obtain proper results.

GAUGE SETTINGS:

Both entrance gauges located at front of machine may be checked or reset by placing a straight edge along the outer edge of the machine plate for the inboard rolls and along the outer edge of the rolls for the button flange. (See Sketch # 1 .)

PRESENT GAUGE SETTINGS:

Inboard Rolls

3-5/64" measured from edge of gauge nearest the rolls.

3-1/8" measured from edge of gauge farthest from rolls. (As shown in Sketch # 1.)

AUXILIARY BUTTON FLANGE:

1" measured from edge of gauge nearest the rolls.

1-1/32" measured from edge of gauge farthest from rolls.

The above gauge settings can be modified slightly to suit specific requirements.

TROUBLE CHECKS:

Due to the unusual physical characteristics of certain types of material, it may become necessary to reset the entrance gauge in its entirety. In the event that the material pulls away from the gauge or the lock is not formed properly, the gauge-taper can be increased – or the entire gauge setting may be increased or decreased slightly to achieve required results. Exit gauge bars are set to, but not against, the formed edge of material when emerging from the machine.

In running certain types of material, it may be necessary to add a slight lubricant to the edge of the sheet being formed to aid the flow of material into the finished lock. The above may be required if the 1/8" return hem does not form properly – if this hem is irregular in nature or tends to wave at edge of formed section – or entrance gauge adjustments do not correct or compensate for proper formation. This lubricant is any light machine oil applied either manually or by a felt wiper pad mounted on the machine.

To obtain the best lock, it will be necessary to insure that the material is in contact with the entrance-starting gauge throughout the complete length of the sheet being formed. Certain materials, as well as hold-down adjustment may have a tendency to allow the material to drift away from the gauge. When this occurs the

lock will be improperly formed – and you may also lose the hem-return. The same condition may exist if the entrance gauge is not set correctly.

STRAIGHTNESS:

Raising or lowering the adjustable gauge bar on the exit end of the machine can eliminate upward or downward bow. (See Sketch # 3.) Lowering the exit bar and putting pressure slightly on the formed lock can compensate upward bow. A downward bow shows too much pressure against material – raise bar slightly. Should the auxiliary button flange shape bow downward, a thin shim can be placed onto the tabletop to apply slight pressure to the underside of the material thereby straightening the formed section.

Note: the # 1 roll station punch position can be shimmed out away from the machine plates to locate the punch closer to the bend line thereby achieving a tighter fit on the snap. See Warning note for proper roll positioning.

WARNING:

The gauge setting should not be made while #1 station is shimmed away from its normal location. The Top # 1 roll is fastened to the shaft by a bolt and washer. The bottom roll is held to the shaft by a key placed into the rolls and is not restrained but held in place by a shoulder on Top #1 roll and should be allowed to float. The shim, if required, should be placed behind the top roll only.

LUBRICATION:

There are seven Ale mite fittings located on the underside of the stand. These fittings are for the high-speed reduction bearings, which should be lubricated after every four hours of operation. Lubricate gears periodically as required. Recommended lubricant: Lubricant standard viscous # 3 (a product of the Standard Oil Co.) or equivalent.

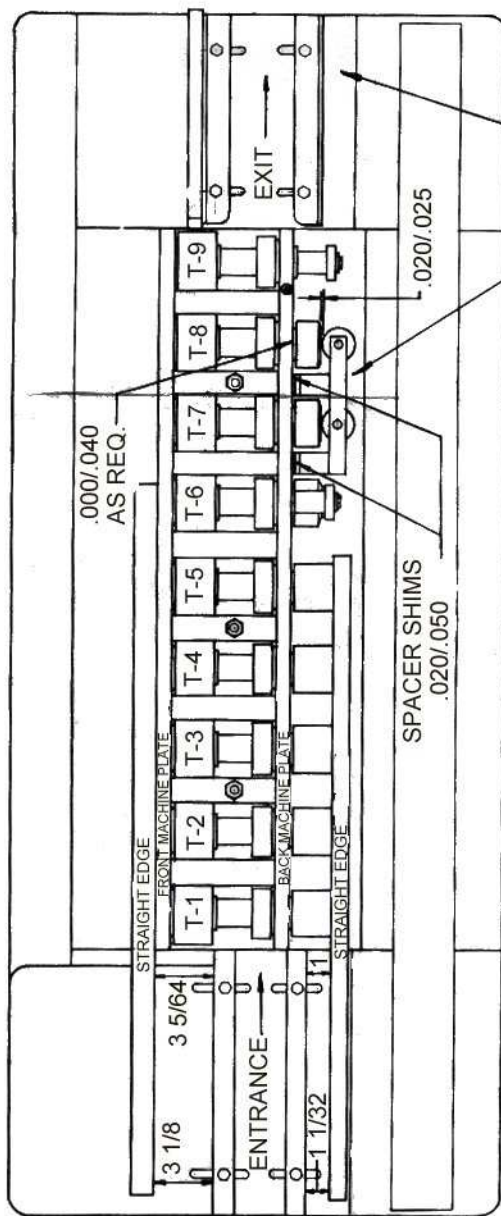

TOP VIEW
 ENTRANCE AND EXIT LOCATIONS
 AND ADJUSTMENT POSITIONS
 SKETCH #1

SEE SKETCH #2
 SEE SKETCH #3

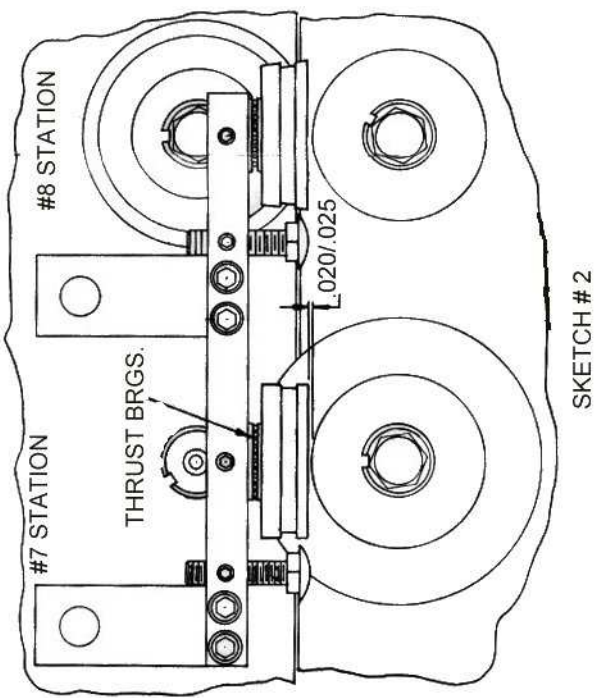
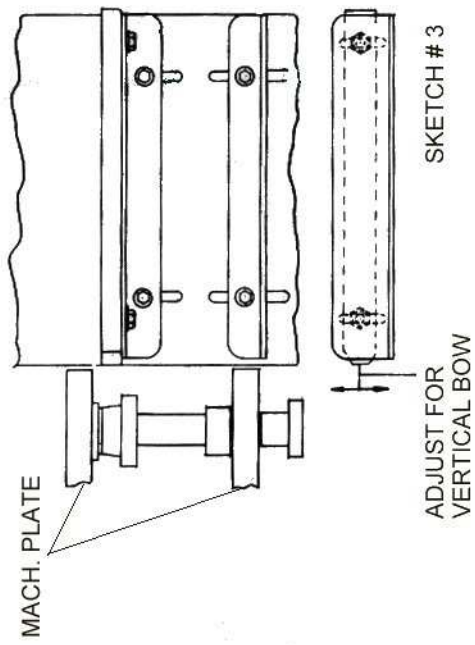

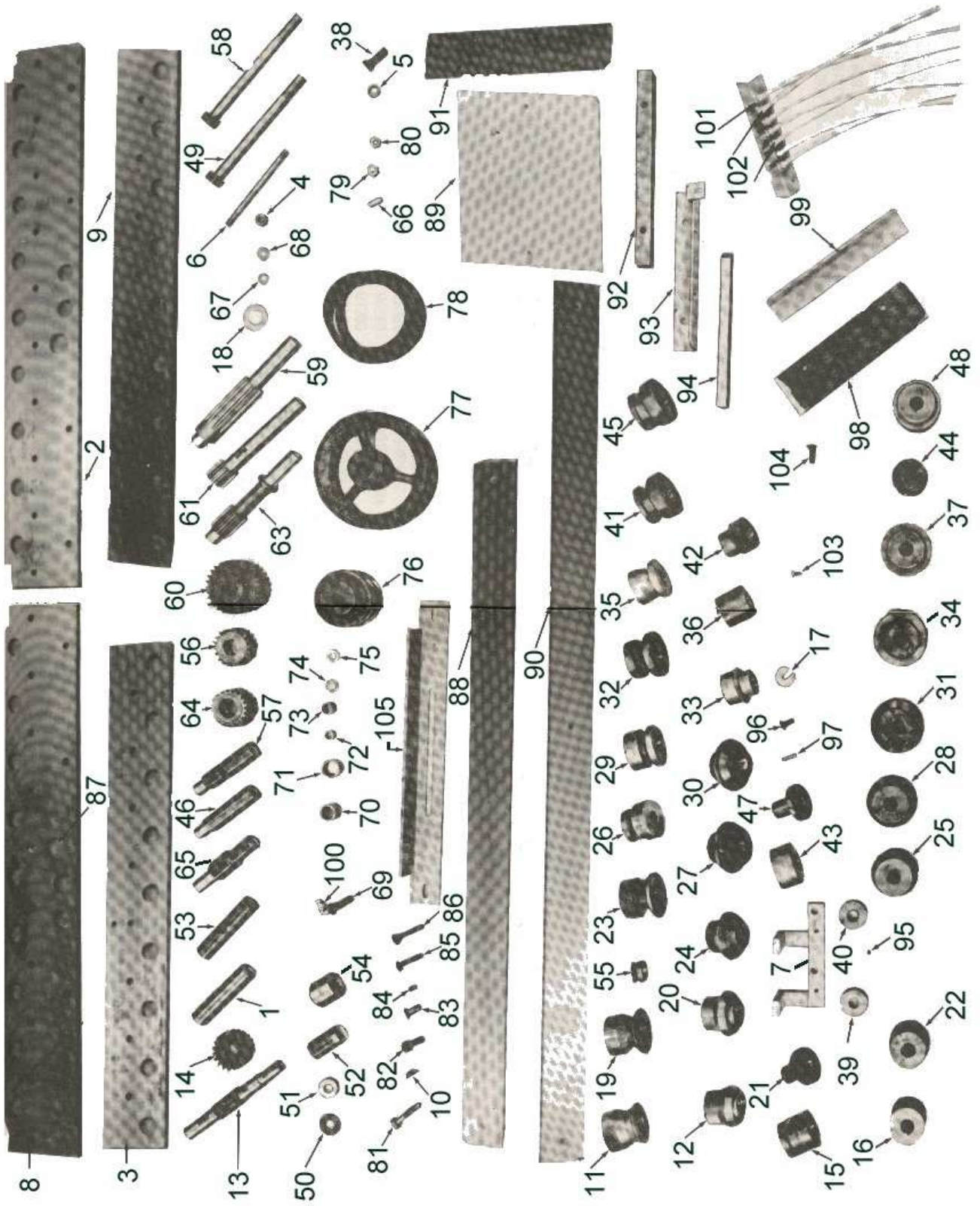

Parts for 9 Station Button Lock			
Fine No.	Part No.	Description	No. REQ'D.
1	BL795630099	PLAIN SPACER	14
2	BL795060089	LOWER BACK PLATE	1
3	BL795060100	UPPER FRONT PLATE	1
4	BL695033198	CONICAL SPRING WASHER 10 dia.	20
5	BL695033201	10.5 DIA X 18 X 1 WASHER	4
6	BL795160134	Stud M8 – 1.25 x 165.1 mm	2
7	BL795200103	IDLER ROLL BRACKET	1
8	BL795060085	LOWER FRONT PLATE	1
9	BL795060101	UPPER BACK PLATE	1
10	BL600123917	15 WOODRUFF KEY	39
11	BL795000064	20 BLF T-1 FORMING ROLL	1
12	BL795000071	20 BLF B-1 FORMING ROLL	1
13	BL795680079	ROLL SHAFT	18
14	BL795380095	DRIVE GEAR	18
15	BL795000118	T-1 FORMING ROLL AUX.	11
16	BL795000109	B1 FORMING ROLL AUX.	1
17	BL795830128	WASHER C SHAPED	15
18	BL795630161	COPPER SPACER I 25.6 ID x 44.5 OD x 1.5mm	63
18A	BL795630162	COPPER SPACER II 25.6 ID x 44.5 OD x 1.5mm	6
19	BL795000163	20 BLF T-2	1
20	BL795000072	20 BLF B-2 FORMING ROLL	1
21	BL795000164	T2,3,4,5,6 FORMING ROLL	5
22	BL795000093	B-2 FORMING ROLL AUX.	1
23	BL795000065	20 BLF T-3 Forming Rolls	1
24	BL795000073	20 BLF B-3 FORMING ROLL	1
25	BL795000110	B-3 FORMING ROLL AUX.	1
26	BL795000068	20 BLF T-4 Forming Rolls	1
27	BL795000074	20 BLF B-4 Forming Rolls	1
28	BL795000112	B-4 FORMING ROLL Aux.	1
29	BL795000066	20 BLF T-5 FORMING ROLL	1
30	BL795000075	20 BLF B-5 FORMING ROLL	1
31	BL795000113	B-5 FORMING ROLL AUX.	1
32	BL795000070	20 BLF T-6 FORMING ROLL	1
33	BL795000076	20 BLF B-6 FORMING ROLL	1
34	BL795000114	B-6 FORMING ROLL AUX.	1
35	BL795000067	20 BLF T-7 FORMING ROLL	1
36	BL795000077	20 BLF B-7 FORMING ROLL	1
37	BL795000115	B-7 FORMING ROLL AUX.	1
38	BL795160086	IDLER PINS	2

39	BL795000124	T-7 IDLER ROLL	1
40	BL795000178	T-8 IDLER ROLL	1
41	BL795000179	20 BLF T-8 Forming Roll	1
42	BL795000165	20 BLF B-8 B-9 FORM. ROLL	2
43	BL795000166	T-8 FORMING ROLL	1
44	BL795000167	B-8 FORMING ROLL	1
45	BL795000168	20 BLT T-9 FORMING ROLL	1
46	BL795630078	IDLER SPACER PLAIN	5
47	BL795000169	T-9 FORMING ROLL	1
48	BL795000170	B-9 FORMING ROLL	1
49	BL795160091	Hex Head STUD ASSEMBLY	1
50	BL695033196	16 X 4.7625 MM WASHER	1
51	BL795033199	CONICAL SPRING WASHER 10 dia. washers 16mm	24
52	BL795830111	SADDLE WASHER	3
53	BL795630097	SPACER DRILLED on Center	3
54	BL795630171	SPACER	2
55	BL795000069	IDLER ROLL 2,3	1
56	BL795380080	IDLER GEAR	7
57	BL795630172	SPACER DRILLED on center idler	2
58	BL795160091	Hex Head STUD ASSEMBLY	2
59	BL795680104	1ST DRIVE SHAFT	1
60	BL795380081	DRIVEN GEAR Phenolic	1
61	BL795680090	2ND DRIVE SHAFT	1
63	BL795680105	3RD DRIVE SHAFT	1
64	BL795380096	MAIN IDLER GEAR	1
65	BL795630083	MAIN IDLER SPACER	1
66	BL695053397	9.525 x 25.4 mm DOWEL	2
67	BL695033202	10 X 1.3208 WASHER	2
68	BL695033203	10 X 1.5875 WASHER	15
69	BL795160107	LUBE BOLT	1
70	BL795080173	B1416 TORR. BEARING	7
71	BL795080174	B1612 TORR. BEARING	38
72	BL795080125	B88 TORR. BEARING	2
73	BL795080020	B1012 TORR. BEARING	1
74	BL795080176	NTA 815 TORR. BEARING	2
75	BL795080177	TRA 815 BEARING	4
76	BL795710180	2 BK 40 7/8 SHEAVE	1
77	BL795710126	2 BK 80 H1 SHEAVE	1
78	BL795100133	5L 540 BELT	1
79	BL695012806	10-1.5 H.N. HVY. S.F.	4
80	BL695023077	10-1.5 JAM NUT S.F.	2
81	BL695012807	M12 -1.75 X 57.15 HHCS	2
82	BL695012799	M12-1.75 X 25.4 FLAT HEAD	1
83	BL695012798	M12-1.75 X 25.4 HEX HEAD	4
84	BL695012808	M8-1.25 X 8 SSS	3

85	BL695012809	M8-1.25 X 44.45 CB	3
86	BL695012810	M8-1.25 X 50.8 CB	1
87	BL795080129	HJ 162412 TORR. BEARING	2
88	BL795180181	MATERIAL SUPPORT B.L.F.	1
89	BL795720182	ENTRANCE TABLE PAD FEM	1
90	BL795180183	MATERIAL SUPPORT	1
91	BL795720184	ENTRANCE TABLE PAD	1
92	BL795030117	ENTRANCE GAUGE BAR	1
93	BL795420116	EXIT GAUGE ASSEMBLY	1
94	BL795030185	HOLD DOWN BAR	1
95	BL695012811	M6-1 X 10 SSS	2
96	BL695012812	M8-1.25 X 25.4 HHCS	1
97	BL795530186	4.7625 SQ. X 22.225 KEY	17
98	BL795060187	EXIT BASE PLATE	1
99	BL795420188	EXIT GAUGE	1
100	BL795140189	ANGLE BODY	1
101	BL795260192	886 L FEMALE COUPLING	7
102	BL795820191	NYLA TUBING	AR
103	BL695012813	M6-1 X 12.7 HHCS	2
104	BL695012814	M8-1.25 X 25.4 C.B.	10
105	BL795060190	MOTOR BASE	1
106	BL796000001	T & B Male roll set	18
107	BL796000002	T & B Female roll set	18
108	BL796000003	15 Amp Switch LGMCCB	1
109	BL796000004	Electrical Switch Cover	1
110	BL796000005	Steel Drive Gear	1
111	BL796000006	Idler Gear Steel Spacer	2
112	BL796000007	30 Amp Switch LGMCCB	1
113	BL796000008	V-Belt B51 /Single Phase	1
114	BL796000009	Sheet Metal Cabinet	1
	BL796000010	Complete B/L Head	1
	BL2L240	Bushing, Split Taper	
	BL2L314	Sheave, Two Groove	
	BL3X533	Drive Pulley, Two Groove	
	BL6K633	5 HP Motor, Single Phase	